

Installation Instructions

Alpha Premier Pack Extra

(Part No. 3.024288)

For use with Alpha condensing boilers

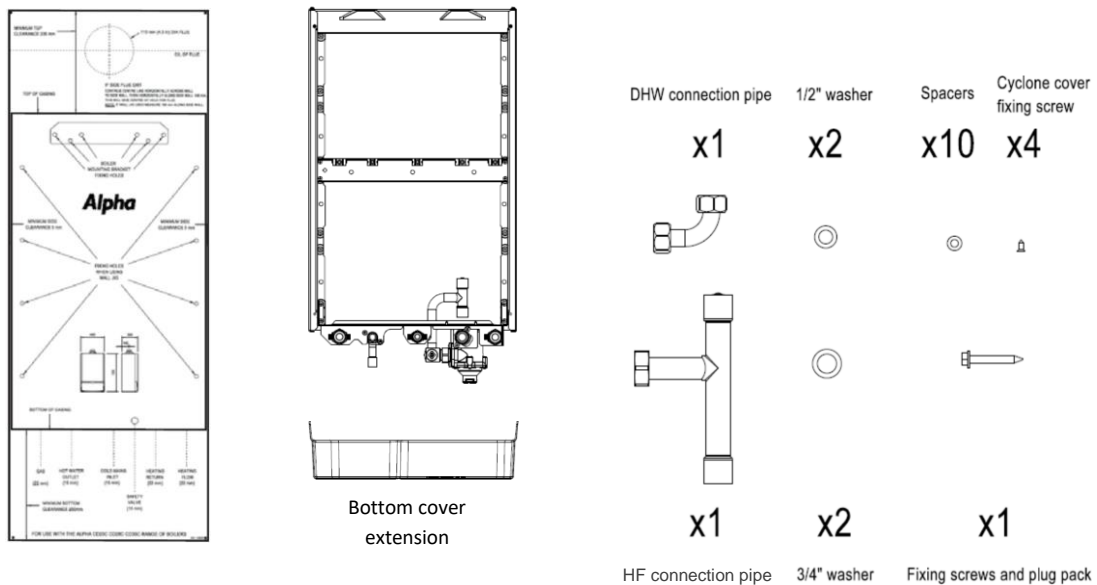

Fig 1. Kit contents

1. INTRODUCTION

The Alpha Premier Pack Extra is only suitable for use with Alpha boilers originally supplied with *threaded* type isolation valves. It must be installed in accordance with these instructions and the installation instructions supplied with the boiler. The kit comprises of a wall jig fitted with a magnetic cyclone and pipe clips, wall template, flow and return split tails, bottom tray, screw pack and wall spacers. The wall jig has been designed to be fitted to the wall before the boiler, allowing the pipework to be pre-fitted. The pipework can be installed vertically upwards and downwards using the flow and return connections supplied on the jig.

Note: As the wall jig adds 45 mm to the depth of the boiler, clearances and flue measurements need to be adjusted accordingly.

2. INSTALLATION

a. Fit the Wall Jig - See Fig. 2

Tape the wall template to the wall in the required position, making sure it is level. Mark the positions of the eight fixing holes for the wall jig as shown on the template and mark the flue position.

Out of the eight holes marked choose four that are suitable then drill the four holes using a 10 mm drill. Insert the wall plugs provided or use suitable fixing for the wall material.

If a vertical or side flue is to be used, ensure that 45 mm is added to the distance from the centre of the flue hole to the wall on which the boiler is to be mounted. This is to allow for the depth of the wall jig. For horizontal flues use a 110 mm core drill cut the hole for the flue.

Secure the wall jig to the wall using the screws provided or suitable fixings for the wall material, ensuring it is level and flat against the wall. The wall spacers supplied may be placed between the wall and the jig if the wall is not flat.

Note: the jig must be flat against the wall and the boiler flat against the jig and ensure the sides A and B of the jig are vertical.

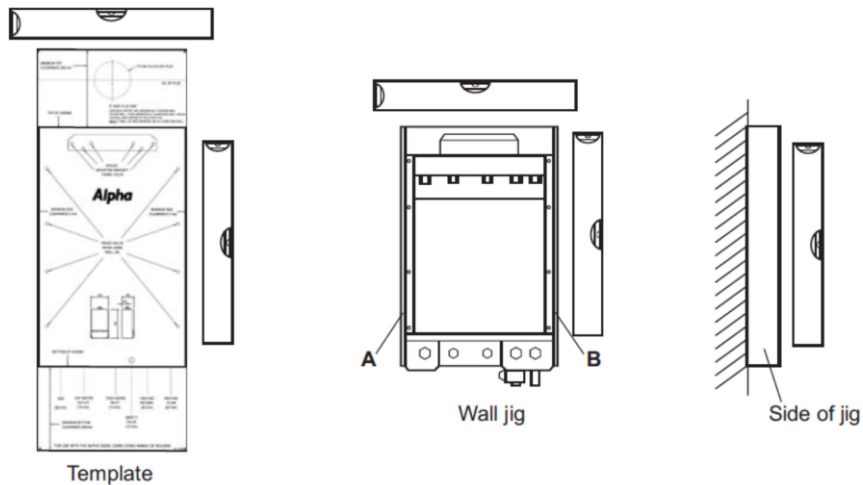

Fig. 2

b. Pipework Connections - See Fig. 3

Connect the system pipework to the jig using the copper pipework tails supplied.

Gas/Hot/Cold Water

Use gas and cold water copper tails supplied with boiler. They may be turned upwards or downwards to suit piping from above or below.

Hot water copper tail supplied pre-fitted to jig. It may be turned upwards or downwards to suit piping from above or below.

CH Return

- The CH return copper tail (fitted to the Cyclone filter) is supplied ready for bottom exit pipework.
- For top *and* bottom exit CH return pipework installations, the factory fitted factory soldered blanking disc will need to be carefully cut off.
- For top exit *only* pipework the factory soldered blanking disc should be carefully cut off and the downward connection then blanked off/used as a drain off point, etc. by the installer.

CH Flow

- The CH flow copper tail is supplied inside the accessory pack. For bottom exit only pipework, fit the copper tail with the open end facing downwards.
- For top *and* bottom exit CH flow pipework installations, the factory fitted factory soldered blanking disc should be carefully cut off.
- For top exit *only* pipework, rotate the CH flow copper tail so the outlet faces upwards. Note: If required, the factory soldered blanking disc can be carefully cut off and the downward connection then used as a drain off point.

Notes:

Ensure pipework is adequately clipped and installed straight and true, otherwise later fitting of the boiler/isolation valves may not line up correctly.

Clips are provided on the jig for securing the pipework at the rear of the boiler for top exit installations.

When soldering pipework into the copper tails, ensure that the boiler/isolation valve are NOT fitted, otherwise damage may be caused.

Thoroughly flush all pipework as described in the instructions supplied with the boiler

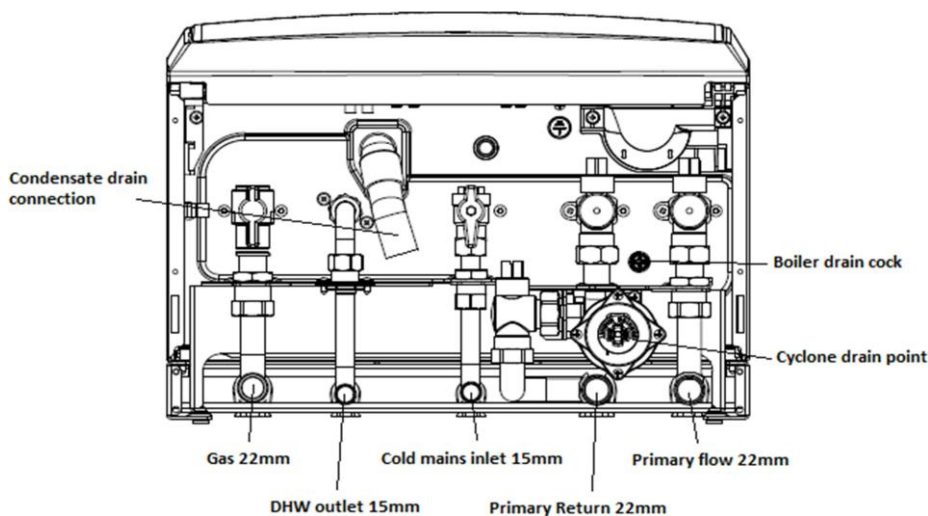

Fig.3

Note: When fitting an Alpha system boiler the DHW connections on the jig are not used and can be removed.

c. Fit the Boiler to the Jig - See Fig. 4

Lift the boiler and lower it onto the bracket at the top of the jig (1), whilst keeping the bottom of the boiler held forward. When the boiler is located on the top bracket, let it rest against back onto the jig (2).

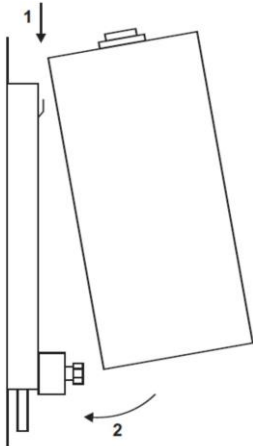

Fig.4

d. Fit boiler isolation valves

The gas/cold water/heating flow and return isolation valves supplied with the boiler should be used.

The DHW connection elbow supplied with the jig kit should be used for this connection

Fit the isolation valves/DHW connection, inserting the fibre washers provided between each union connection and tighten the joints.

Note: Check **all** connections are tight.

- e. Connect the flue, connect the electrical supply, fill the boiler and commission the system as described in the instructions supplied with the boiler.

Fitting the Cyclone cover (premium models only)

- f. A bottom cover extension is supplied with the Premier Pack Extra. Offer the extension up to the bottom cover (premium models only) and fix into position using the screws provided.

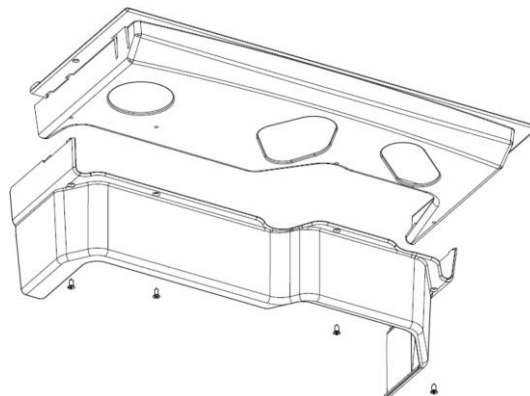

Cleaning the Magnetic Cyclone (yearly service)

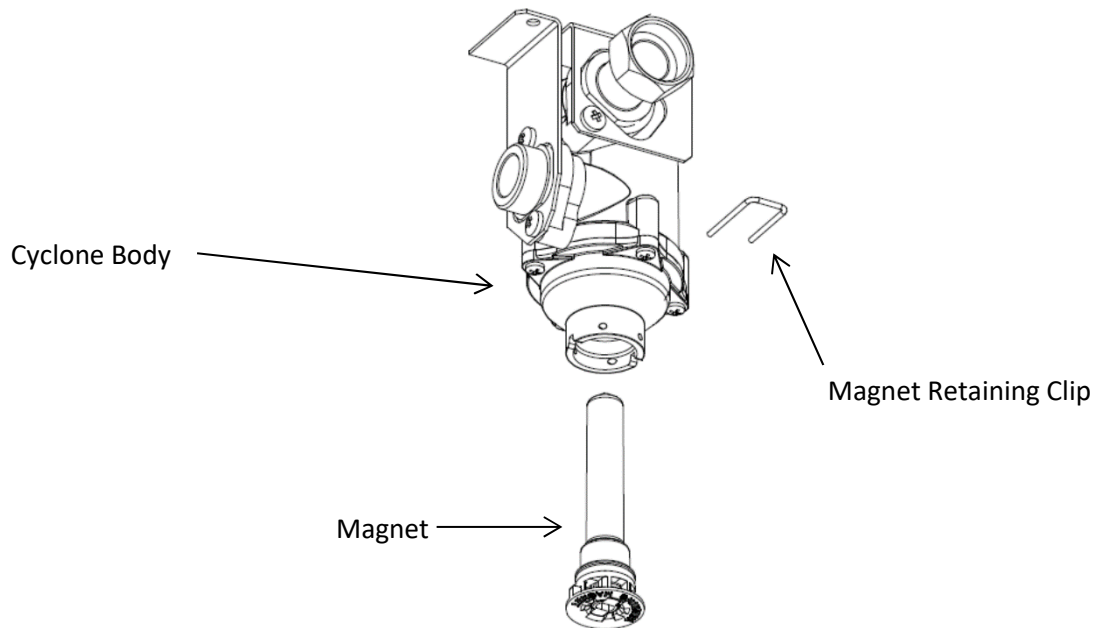

1. Close the isolation valves connected to the cyclone and the boiler return.
2. Place a bucket underneath the Cyclone and remove the retaining clip by pulling it forwards with a pair of pliers.
3. Pull the magnet downwards to withdraw it from the Cyclone body; a small amount of water will flow out of the Cyclone.
4. Using a cloth wipe any magnetite from the magnet.
5. Reassemble in reverse order

Alpha

HEATING INNOVATION

Alpha Therm Limited.

Nepicar House, London Road, Wrotham Heath,
Sevenoaks, Kent TN15 7RS

Tel: 0344 871 8764

email: info@alpha-innovation.co.uk

website: www.alpha-innovation.co.uk

part no. 1.041585

rev. ST.003466/000