

### Description

Stainless steel manifold for 2 up to 12 heating circuits for distribution, shut off and balancing of the heating/cooling water flow of radiant panel heating/cooling systems in compliance with BSEN 1264-4. The flow rate for each heating circuit can be continuously adjusted via a regulating shut-off valve integrated in the return circuit.

- M30x1.5 valve connection for all common actuators (optional accessory).
- Precise adjustment even at high flow rates.
- Premium quality O-ring valve gaskets (EPDM) ensure permanent ease of operation and high durability.
- 1" MT flat-sealing connections to heat generator, connection to heating circuits via 1" eurocone for clamp ring screw connections.
- Includes an end set with 3/4" swivel connection for shut-off, filling, draining and flushing.

- Ready-mounted on wall bracket, low-noise pipe clamps in accordance with DIN 4109.
- A wide range of supplementary systems, such as pump groups, hydraulic control units for manifolds, heat interface units and many more.

### Technical data

Performance	
Application	Underfloor heating/cooling systems
Function	Temperature control for individual rooms using actuators Automatic flow control Shut-off / filling / draining / flushing / venting
Max. operating pressure	10 bar
Flow range	The flow rate can be set continuously within the specified range: 30 to 300 l/h.
Differential pressure ( $\Delta p_V$ )	Max. differential pressure: 60 kPa (<30 dB(A)) Min. differential pressure: 30 to 150 l/h = 17 kPa / 150 to 300 l/h = 25 kPa
Temperature	Max. operating temperature: 70°C Min. operating temperature: -5°C
Pipe connections	Manifold: 1" FT End kit: 1" FT Connection with heating circuits: 3/4" with euro cone

Materials	
Manifold	Stainless steel 1.4301
Screw connections / End kit	Nickel-plated brass
O-rings	EPDM
Valve disk	EPDM
Pressure spring	Stainless steel
Top part of thermostat	Brass, PPS
Spindle	Stainless steel spindle

### Dimension and Characteristic Components

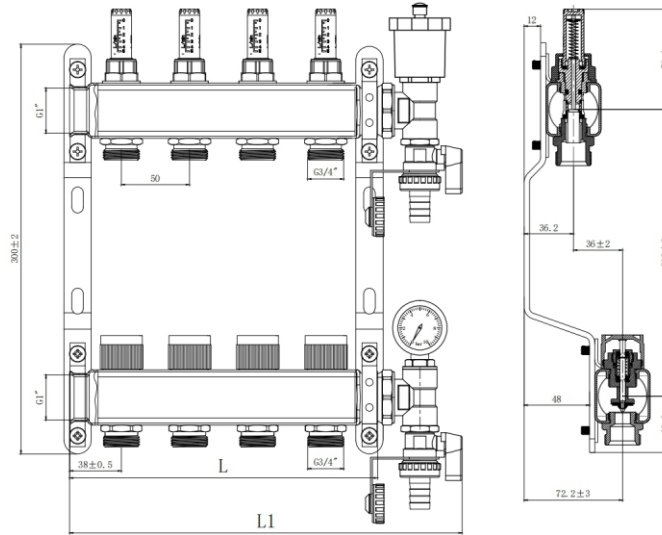

Circuits	2	3	4	5	6	7	8	9	10	11	12
L [mm]	126	176	226	276	326	376	426	476	526	576	626
L1 [mm]	188	238	288	338	388	438	488	538	588	638	688

### Hydraulic Characteristic

pressure drop diagram

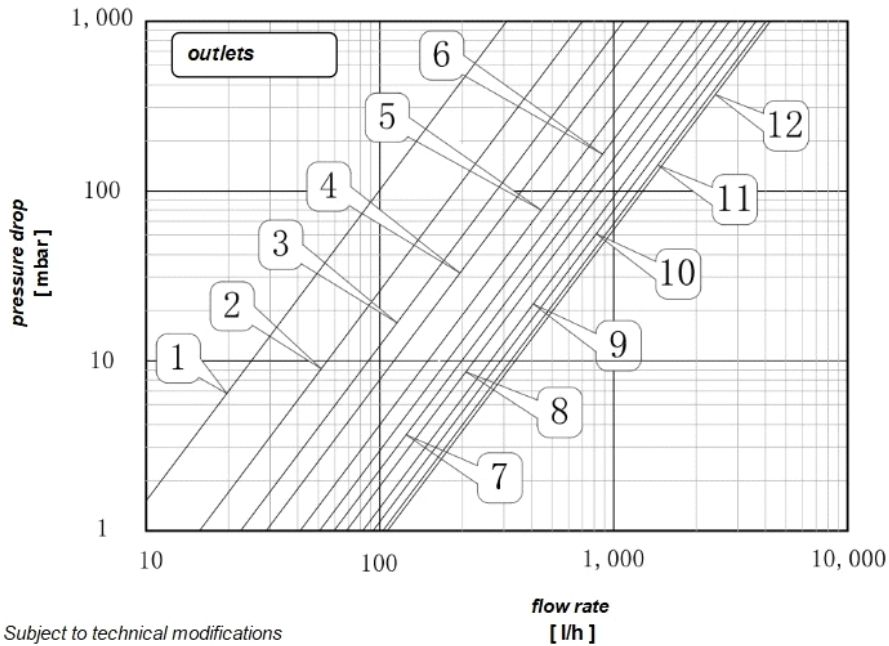

Number of heating circuits	1	2	3	4	5	6	7	8	9	10	11	12
Kvs(m <sup>3</sup> /h)	0.31	0.71	1.12	1.43	1.84	2.15	2.5	2.8	3.29	3.66	4.03	4.25