

TECHNICAL DATA SHEET

D-Shape Trade Solutions WC Set

DC14065

No.	Description	Product Code	Fixings included	Gross Weight
1	Close Coupled Cistern	DC14067	YES	13KG
2	Secure Fix Slim Wrapover Seat	DC4044-SF	YES	3KG
3	Open Back CC WC	DC14066	YES	25KG

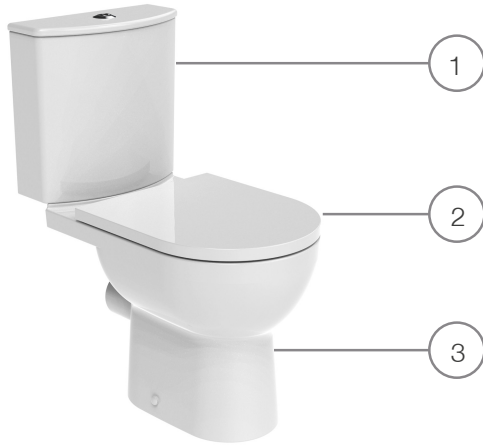

Floor Fixings

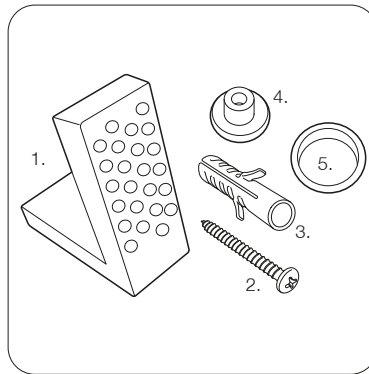

- 1. 2x Nylon Floor Bracket
- 2. 4x Stainless Steel Screws
- 3. 2x Nylon Screw Plugs
- 4. 2x Nylon Screw Collars
- 5. 2x Nylon Collars Caps (Metalic Finish)

Spare Code: SP14211

DIMENSIONS

DIAGRAMS NOT TO SCALE | ALL DIMENSIONS IN MM | TOLERANCE OF ± 5MM
ALL PRODUCTS CONFORM TO BRITISH STANDARDS

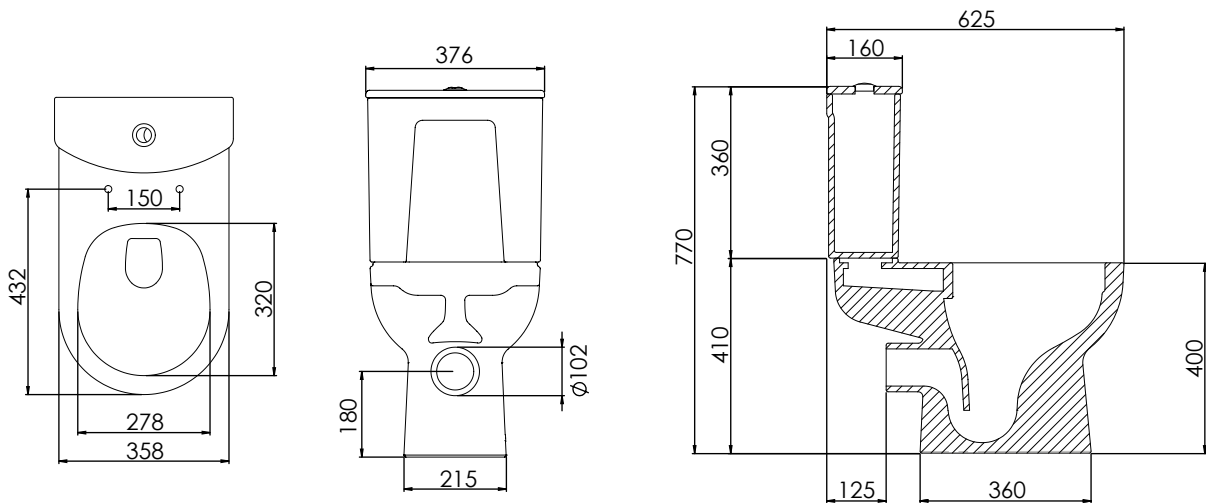

*Dimensions are subject to change, customers are advised to measure actual product before commencing installation.
**Fixing point dimensions are for guidance only. The positions of fixings must be checked when product is received.

FAQs

Q - Where is the inlet valve?
A - Bottom inlet, back right or left of pan. WC is supplied with a blanking plug for the hole that is not used.

Q - What is the flush volume?
A - 6/4L

Q - Can the flush volume be reduced to save water?
A - Yes, the flush volume can be reduced to 4.5L/3L. Please see instructions documents for a guide to changing the flush volume.

Q - Are there any other compatible seats?
A - Yes, a PP seat is available using product code DC4043 (seat only) or DC14068 (full WC set including PP seat).

Q - Rim Type?
A - Rimless

Q - What finish is the ceramic glaze?
A - Alpine White

Q - What finish is the flush button supplied with the cistern?
A - Chrome

Q - Are there replacement buttons?
A - Yes, compatible with black (TR9026), brass (TR9038) or gun metal (TR9047) buttons.

Q - Can the items from the WC set be purchased individually?
A - Yes, using individual product codes: DC14066 (WC pan), DC14067 (Cistern) and DC4044-SF (WC Seat).