

Sauris Mono

Kitchen Sink Mixer Tap
SMS172/005



DevaTM by METHVEN

Installation Guide

Contents

Congratulations on your purchase of your new Sauris Mono Kitchen Sink Mixer. Our fitting instructions have been created with you in mind to provide you with all the information you require and, if you need any further help, please don't hesitate to contact our customer care team on 0800 195 1602

Page Description	Page
General safety information	3
Features	4
Components list	5
Installation Instructions	6
Troubleshooting	7
Warranty information	8



General Safety Information

Methven recommends this product is installed by a competent person in compliance with all relevant regional regulations.

Remove all packaging and check the components for damage before starting installation.

This product must not be modified in any way as this will invalidate the guarantee.

It is the responsibility of the installer to ensure a waterproof seal is achieved, after installation all connections must be checked for leaks.

All outlets used primarily for personal hygiene shall deliver water at a safe temperature as per regional regulations.



Sauris Mono Kitchen Sink Mixer

Product Code: SMS172/005

Finish: White

Construction: Brass

Valve/Cartridge type: 1/4 Turn ceramic disc

Supply: Suitable for low pressure plumbing systems

Working Pressures: 0.1 - 5.0 bar

Inlet Connections: 15mm Copper

Flexi or Copper: Copper tails

- Swivel spout
- Dual flow

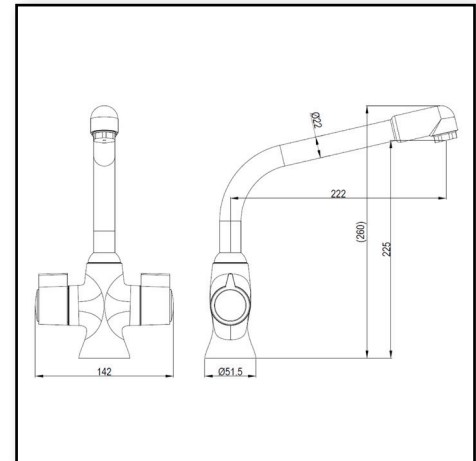

Components List

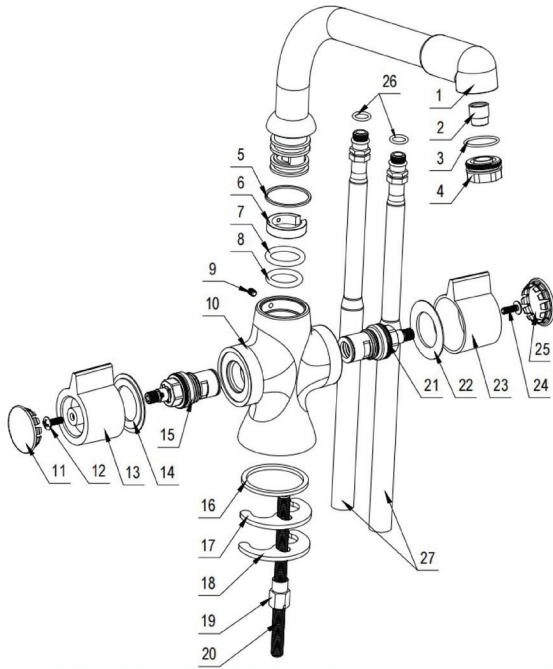

1	Spout
2	Aerator
3	O-Ring
4	Aerator Housing
5	O-Ring
6	Cir-clip
7	O-Ring
8	O-Ring
9	Grub Screw
10	Sink Mixer Body
11	Handle Cover
12	Screw
13	Handle
14	Cold Indice
15	¼ Turn Ceramic Disc
16	Base Plate
17	Rubber Horseshoe Washer
18	Metal Horseshoe Washer
19	Fixing Kit Nut
20	Fixing Kit Threaded Bar
21	¼ Turn Ceramic Disc
22	Cold Indice
23	Handle
24	Screw
25	Handle Cover
26	O-Ring
27	Copper Tails

SMS172/005

Installation Instructions

Prior to installation please ensure all supply pipes have been thoroughly flushed through to remove any debris. Isolating valves must be fitted in a convenient position to allow future servicing of the fitting.

1. Screw the threaded fixing bar into the bottom of the mixer body
2. Screw both copper tails into the tap body, ensuring that the O-Ring on the tail is positioned inside the tap body, this should only need to hand tight. Do not use PTFE tape or similar to create the seal.
3. Offer the tap up to the hole in the sink.
4. On the underside of the sink fit the rubber and metal horseshoe washers onto the threaded fixing bar mounting hole.

Note: Plastic Triangle - If required an under sink mounting triangle can be purchased, this should be used on thin work surfaces to help distribute the weight of the tap and provide a thicker mounting surface for the fixing kit to clamp to.

5. Connect the male end of the tail to the corresponding hot and cold inlets.
6. Reinstate water supply and test for leaks.

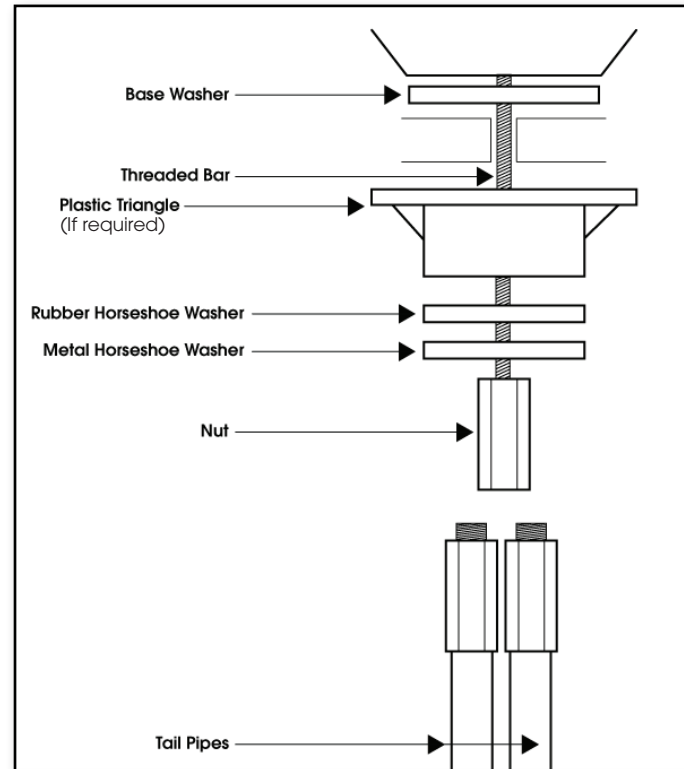

Troubleshooting Guide

SYMPTOM	CAUSE(S)	RESOLUTION
Mixer not turning on	Mains water supply turned off	Turn on mains water supply
	Closed isolation valve	Open isolation valve
No hot water	Cold override	Check if the pressure is balanced. Fit pressure equalising valve.
Low flow rate/no flow	Water supply failure	Investigate water supply, check plumbing and heating system for any faults
	Partially closed isolation valve	Open isolation valve
	Air lock or partial blockage in the supply pipework or hoses	Flush through pipework to ensure removal of debris and any airlocks
	Water being drawn off elsewhere causing pressure changes or instantaneous boiler temperature changes. Ensure minimum pressure is being met	Try not to use other water outlets when using the mixer
Water dripping from the mixer	This is normal for a short time after using the mixer	This is due to residual water tension, the build up of water in the mixture spout
	If water continues to drip, possible issue with the flow control cartridge	Please contact our customer care team
Movement of fitted mixer	Fixing kit loose	Ensure fixing kit nut is sufficiently tightened
	Extra support may be required depending on the surface the tap is fitted to	Please contact our customer care to purchase an under the sink mounting triangle

Warranty Information

Proof of purchase will be required. The guarantee does not cover faults or damage caused by incorrect installation and/or maintenance, ordinary wear and tear, water composition, etc.

*Please see www.deva-uk.com for full terms and conditions of warranty

Cleaning

Your product has a high-quality finish and should be treated with care to preserve the visible surfaces. Never use abrasives or abrasive cleaning agents to clean this product clean regularly with contamination free warm water and a damp soft cloth. Do not use products containing chlorine bleach or hydrochloric acid as these can damage the product.

We have a policy of continuous improvement and reserve the right to change specifications without notice.

METHVEN UK LIMITED
METHVEN EXPERIENCE CENTRE
3/3A STONE CROSS COURT
YEW TREE WAY
GOLBORNE
WARRINGTON
WA3 3JD
UNITED KINGDOM
30.01.2026

TEL: 0800 195 1602
EMAIL: customercare@uk.methven.com
www.deva-uk.com
www.methven.com